

BM10ATS 10 Litre Planetary Mixer

Product Features

- Heavy duty construction
- Belt driven
- Long life gear box
- 3 fixed speeds
- Easy speed shifting
- 15 minute timer

Standard Accessories

- Batter beater
- Dough hook
- Wire whisk
- 10 litre stainless steel bowl
- Wire safety guard
- Scraper



BM10ATS

Optional Accessories

- BM10AT-12-001 Stainless steel bowl to suit 10 litre mixer
- BM10AT-12-002 Batter beater to suit 10 litre mixer
- BM10AT-12-003 AL hook to suit 10 litre mixer
- BM10AT-12-004 Stainless steel wire whip to suit 10 litre mixer

BM10ATS 10 Litre Planetary Mixer

Model BM10ATS

Dimensions

Width 365mm
Depth 453mm
Height 630mm

Electrical Requirements

220-240V, 1P+N+E, 50Hz, 0.25kW

Nett Weight 62kg

moffat.com.au

moffat.co.nz

Australia

moffat.com.au

Moffat Pty Limited

Victoria/Tasmania

740 Springvale Road
Mulgrave, Victoria 3170
Telephone +613-9518 3888
Facsimile +613-9518 3833
vsales@moffat.com.au

New South Wales

Telephone +612-8833 4111
nswsales@moffat.com.au

South Australia

Telephone +613-9518 3888
vsales@moffat.com.au

Queensland

Telephone +617-3630 8600
qldsales@moffat.com.au

Western Australia

Telephone +618-9413 2400
wasales@moffat.com.au

New Zealand

moffat.co.nz

Moffat Limited

Rolleston

45 Illinois Drive
Izone Business Hub
Rolleston 7675
Telephone +64 3-983 6600
Facsimile +64 3-983 6660
sales@moffat.co.nz

Auckland

Telephone +64 9-574 3150
sales@moffat.co.nz

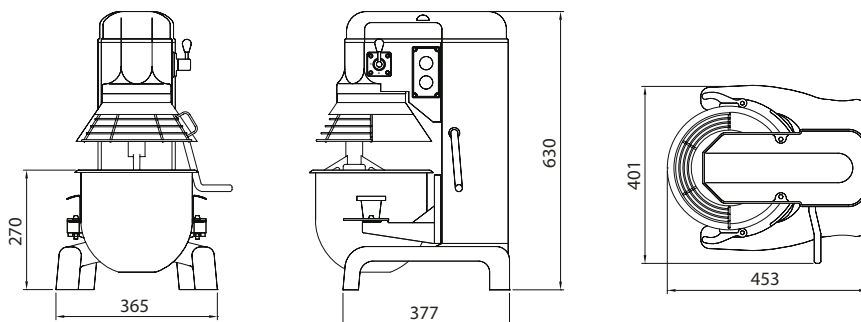

In line with policy to continually develop and improve its products, Moffat Limited reserves the right to change specifications and design without notice.

© Copyright Moffat Ltd
AN.P.01.21

an Ali Group Company



The Spirit of Excellence